

Homework 26.

**Parallel and series connections.**

We learned that most of the real wires have finite resistance (the exception is the superconducting wire, but we will not discuss it here now). We will be using 2 types of wire. One is the ideal wire. We will denote in as a smooth line or straight line. The other type is the real wire, which we will denote as a wobble line (Figure 1).

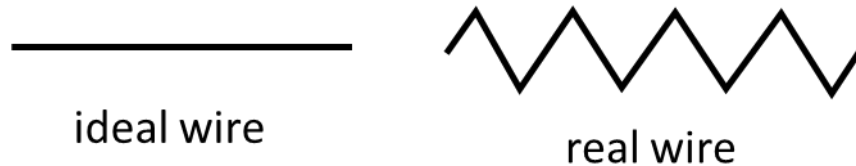

Figure 1. Ideal and real wires.

The ideal wire has zero resistance. If we will calculate the potential difference (voltage) between 2 points, connected with the ideal wire, we will always obtain zero. It follows from the Ohm's law:

$$U = I \cdot R = I \cdot 0 = 0 \quad (1).$$

So, if two points are connected by the ideal wire, the voltage between these points is always zero. A piece of real wire we will call "*resistor*" since it has a finite resistance. We discussed 2 most common ways to connect resistors: *series and parallel*.

Series connection means that 2 or more resistors are connected chainlike, similar to the beads on the thread (Figure 2a). "Parallel connection" means that 2 or more resistors are connected to the same pair of points (Figure 2b).

Resistors, connected in series, share same current. It follows from the charge conservation law.

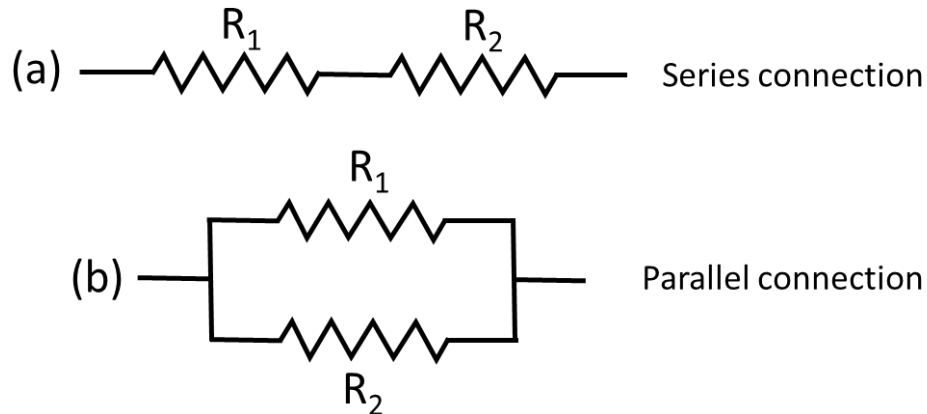

Figure 2. Parallel and series connection.

If a steady current which flows into resistor R<sub>1</sub> (Figure 3a) would have exceeded the current which flows from resistor R<sub>1</sub> into resistor R<sub>2</sub>, then the charge in resistor R<sub>1</sub> would be growing continuously, which is not possible at the steady state conditions.

The total voltage drop across the chain of resistors connected in series is equal to the sum of the voltages at each resistor. So, we have:

$$U_{total} = U_1 + U_2 = IR_1 + IR_2 = I(R_1 + R_2) = I \cdot R_{total} \quad (2)$$

So, for parallel connection  $R_{total} = R_1 + R_2$ .

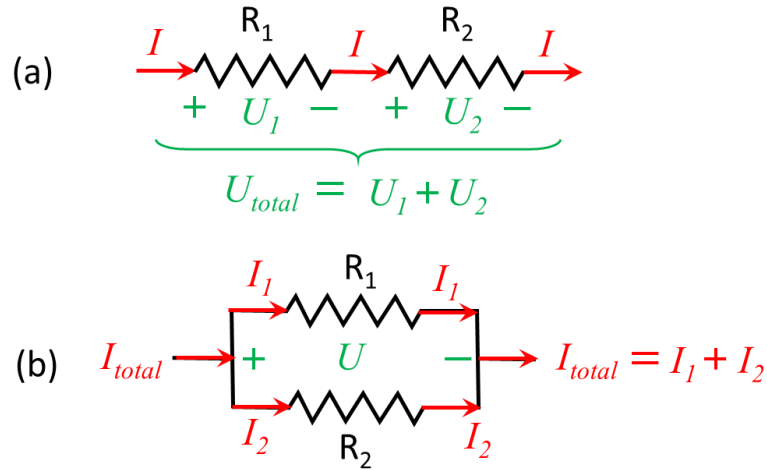

Figure 3. Series and parallel connection of resistors.

For parallel connection voltage drop across all the resistors is the same, but total current is equal to the sum of the currents flowing through each resistor (Figure 3b):

$$I_{total} = I_1 + I_2 = \frac{U}{R_1} + \frac{U}{R_2} = U \left( \frac{1}{R_1} + \frac{1}{R_2} \right) = \frac{U}{R_{total}} \quad (3)$$

So, for series connection:  $\frac{1}{R_{total}} = \frac{1}{R_1} + \frac{1}{R_2}$ . Or, if we have just 2 resistors, connected in parallel:

$$R_{total} = \frac{R_1 \cdot R_2}{R_1 + R_2} \quad (4)$$

We can better understand the difference between parallel and series connections from the picture below:

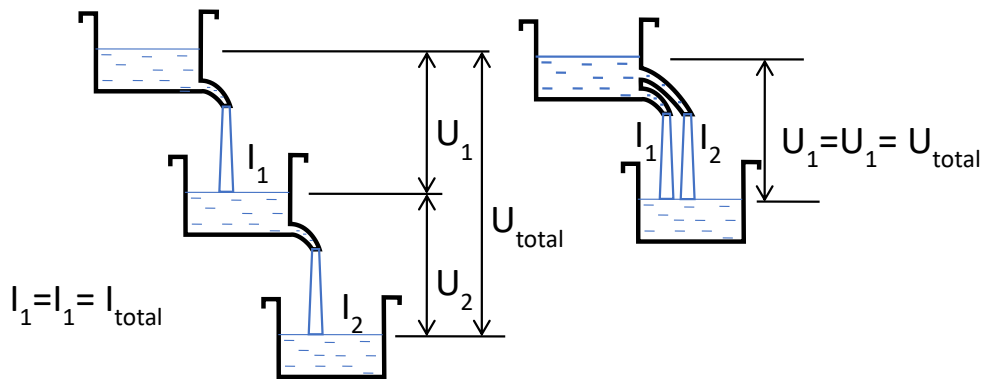

Figure 4. Parallel and series connection as the waterfall cascades.

**Series connection:**  $U_{\text{total}}=U_1+U_2$ ,  $I_{\text{total}}=I_1=I_2$ , which means same current, voltages are added

**Parallel connection:**  $U_{\text{total}}=U_1=U_2$ ,  $I_{\text{total}}=I_1+I_2$ , which means same voltage, currents are added

Problems:

1. Two conductors are connected in series to a voltage source. Resistance of one conductor is 3 times higher than the resistance of the other. How much times will the total current in the circuit change if we will connect these conductors to the same voltage source in parallel?
2. The resistor network below can be replaced with just 1 resistor, connected between points A and B. Resistance of this resistor is called “equivalent resistance of the network”. Find the equivalent resistance:

